

# **PRESSURISATION UNITS**

## **SU1, SUE1, SU2 & SUE2**

**INSTALLATION, OPERATION  
AND  
MAINTENANCE INSTRUCTIONS**

Please fulfil all listed requirements prior to, and during installation and operation of all equipment to prevent any invalidation of any warranty given.

## **GENERAL INSTALLATION**

### **INTRODUCTORY NOTES**

All STREBEL Pressurisation Units operate in a single pump, (duty) or two pump, (duty/standby) format. These units together with the individually sized expansion vessel/s are employed to maintain the ambient cold fill pressure and accommodate the volume changes that occur in sealed heating systems.

Each unit is individually supplied, any system alterations may require a design or setting change.

The full system should be pressure tested and flushed BEFORE connection to the unit or vessel to prevent any damage from metal particles, dirt etc, and to eliminate all leaks.

Under no circumstances must any treatment be introduced into the system via any part of the unit.

Do not use the unit to fill the system, this should be performed with a quick fill pipe.

### **SITE LOCATION**

The unit location should be undercover, dry and freely ventilated. Protection from frost must be ensured.

Reasonable access to all parts of the set and adequate service work space must be provided. A minimum clearance of 350mm above the unit is required if placed back to a wall.

The unit must stand on a level non combustible base, which is capable of adequately supporting the weight of the pressurisation unit, expansion vessel, water content and any ancillary equipment. Points are provided for floor fixing if required.

### **MECHANICAL**

Connect the cold water mains supply via a stop cock and union connection to the break tank ball valve, (on units without a 6" air gap in the break tank a double check valve may be required).

Arrange the overflow to discharge away to a suitably noticeable position.

Using one of the BSP outlets, link into the system on the return side of the boiler, and the suction side of the pump incorporating a minimum two metre anti-gravity loop fitted with automatic air vent. If an intermediate vessel is fitted, installed into the loop with the system side piped into the top and the unit side into the bottom.

The second outlet should be taken to the expansion vessel/s. If these are installed separately it is most important to fit isolation valves and drain cocks to each vessel.

All pipework linked should be suitably sized with a minimum of 22mm up to 6 metres, and 28mm up to 12 metre runs

ALL MUST BE LEFT UNLAGGED.

**Dimensions and weights**

MODEL	A mm	B mm	C mm	Wet Weight kg
SU1	475	475	900	80
SUE1	475	475	900	105
SU2	475	475	900	115
SUE2	475	475	900	118

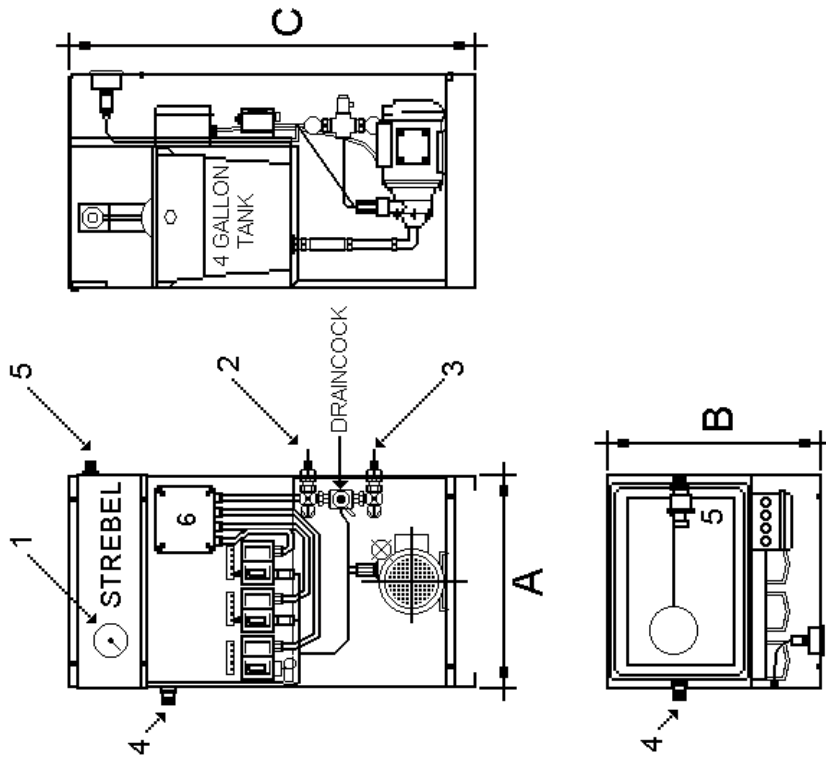

**Key:**

1. System pressure gauge.
2. 1/2" BSP Male system connection.
3. 1/2" BSP Male connection to vessel.
4. 22mm Overflow connection.
5. 1/2" Ball Valve.
6. Terminal box.

**SCHEMATIC INSTALLATION DIAGRAM**

Single system pressurisation units.

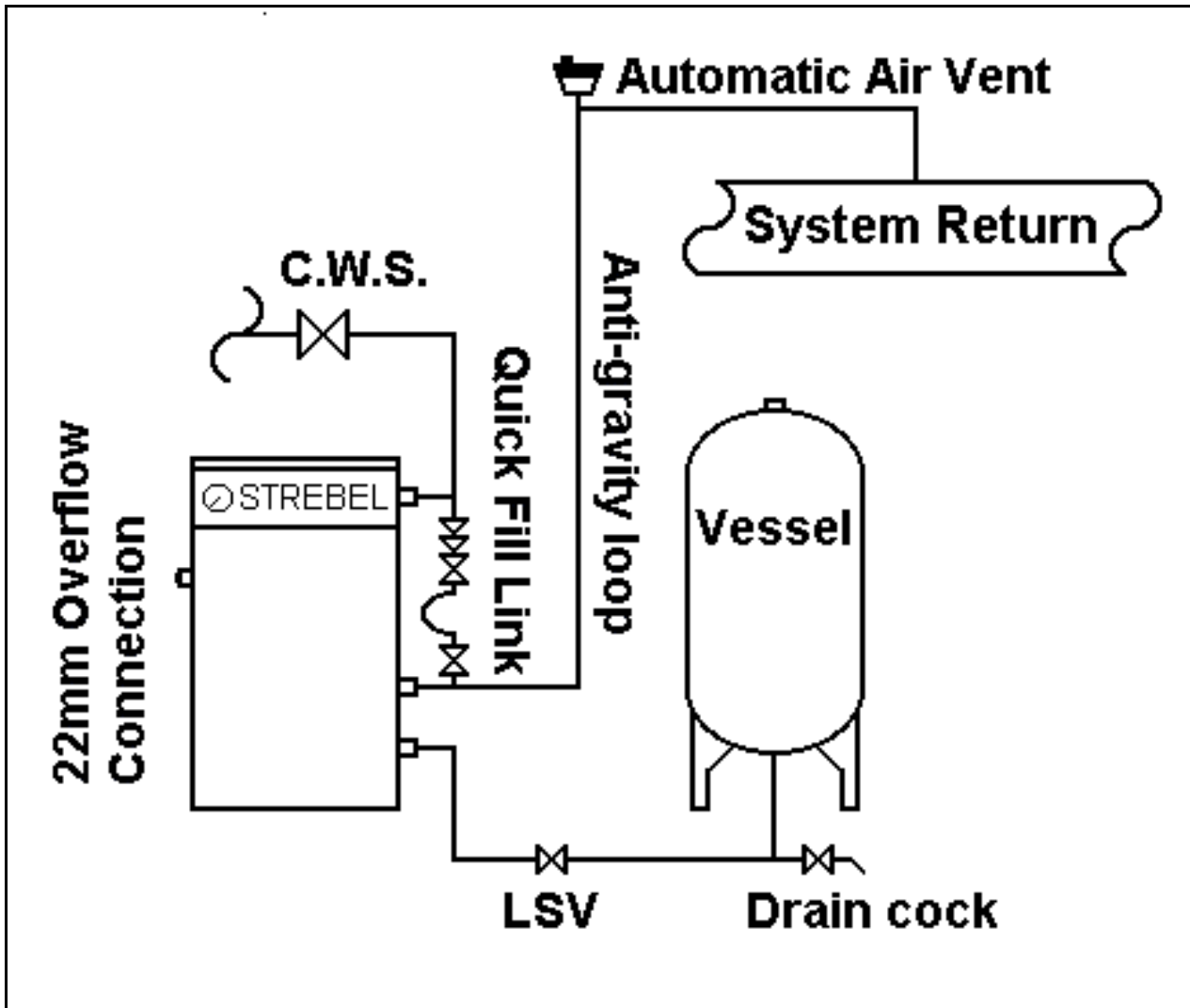

Notes

Do not lag pipework from unit to system or vessel.

Follow wiring diagram for electrical connections.

Quick fill link to be removed after filling system.

Pipework is duplicated for dual system installations.

## **ELECTRICAL CONNECTIONS TO UNIT**

The supply should be brought to the set with suitable trunking or armoured cable, with trunking we recommend that the final metre is connected to flexible conduit to avoid any undue stress or fatigue.

All supply cables should be sized accordingly to accommodate any voltage drop due to long cable runs.

It is recommended that an independent isolator is fitted adjacent to the unit.

The supply fuses should be rated to run one pump or one of a pair in a duty standby unit. (Please refer to the pump plate for electrical details)

All equipment should be earthed.

It is strongly recommended that any supply feeding the volt free contacts for alarms or cut outs is disconnected by the independent isolator.

All connections should be performed by a qualified electrician conversant with the wiring diagram.

### **NOTE**

ALL WIRING DIAGRAMS CAN BE FOUND AT THE REAR OF THIS MANUAL.

---

## COMMISSIONING

These notes are guidelines to engineers who are conversant with sealed systems and pressurisation units. Flow Mech Products can provide a commissioning service for customers where required.

If the unit has been factory set no adjustments after pump priming should be necessary.

**NOTE:** All pumps must be vented prior to any running using the vent plug situated adjacent to the discharge valve. If water is not present, gently open the suction spring check valve to allow flow to reach the vent point, finally replace the plug.

Taking a single pump, single system unit as an example, first set the air charge within the vessel/s to the cold fill pressure required. (See maintenance)

Proceed, setting the high-pressure switch to cut out 0.3 bar below the system safety valve, switch differential being located at the minimum point.

Next set the fixed differential pump control switch to cut in at the cold fill setting and out 0.2 bar above. (min cut in 0.8 bar) It must be noted that this is only possible to set when unit is open to the vessel/s.

During commissioning it may be found advantageous to close down the pump discharge ball valve 40-50% to prevent the pump hunting, this should be left in this position on completion.

Again the low-pressure switch should be set to the minimum differential and cut out set to 0.3 below the cold fill. (with exception of min setting being 0.6 bar)

Most settings can be verified against the gauge, running the pump against a closed manifold and draining down with the integral drain cock.

All fault switch operations should be checked in conjunction with the main control panel.

On units with twin pumps the second pump should be tested by change of the selector switch.

Units with dual systems will require the same method of setting but all switches are duplicated. (please note correct system, vessel, and switch combinations)

## ENHANCED CONTROLS

If a unit is found to have locked out on the low level cut out, the reset/mute button must be depressed to allow the pump to restart. (this will only occur if water level is reinstated)

On units supplied with hand/off/auto switches, the hand mode will run the pump constantly, the auto pump will run the pump via the control pressure switch.

## **MAINTENANCE**

Six monthly checks should be made on all pressurisation units and expansion vessels, the exception to this is the alternation of the duty pump on the twin units via the pump selector switch, which should be monthly.

The maintenance checks should be carried out after the heating or chilled system has been shut down.

All expansion vessels are to have their air charged tested and adjusted if necessary using a good tyre gauge, foot pump or oil free compressor. It must be stressed that this is only performed after the vessel has been isolated, and drained of all water present.

Change the break tank stored water by connecting a hose to the internal drain cock after closing both system outlet valves, reinstate power to the pump and run two tank fulls of water to a suitable waste. (do not run the tank dry) During this operation all the pressure switches can be checked for operation together with the boiler/chiller interlocks. Open the outlet valves after flushing has been completed and drain cock closed.

On enhanced units all overloads should be tested and reset, and all faulty bulbs and neon lamps should be replaced.

All pumps are fitted with maintenance free mechanical seals and sealed for life bearings which cannot be greased, if the seal should fail the break tank should be drained the pump removed and the complete two part seal replaced. Pump priming must take place after replacement.

Pressure switches rarely fail but should this happen a straightforward changeover is possible taking care to replace the cables into the same terminal connections. Reset the switch as described in the commissioning details.

All work undertaken should only be performed by a competent person conversant with sealed system pressurisation units.

A full maintenance programme can be provided by Strebel Ltd upon request.

# **WIRING DIAGRAMS**



# Pressurisation Unit - SU1

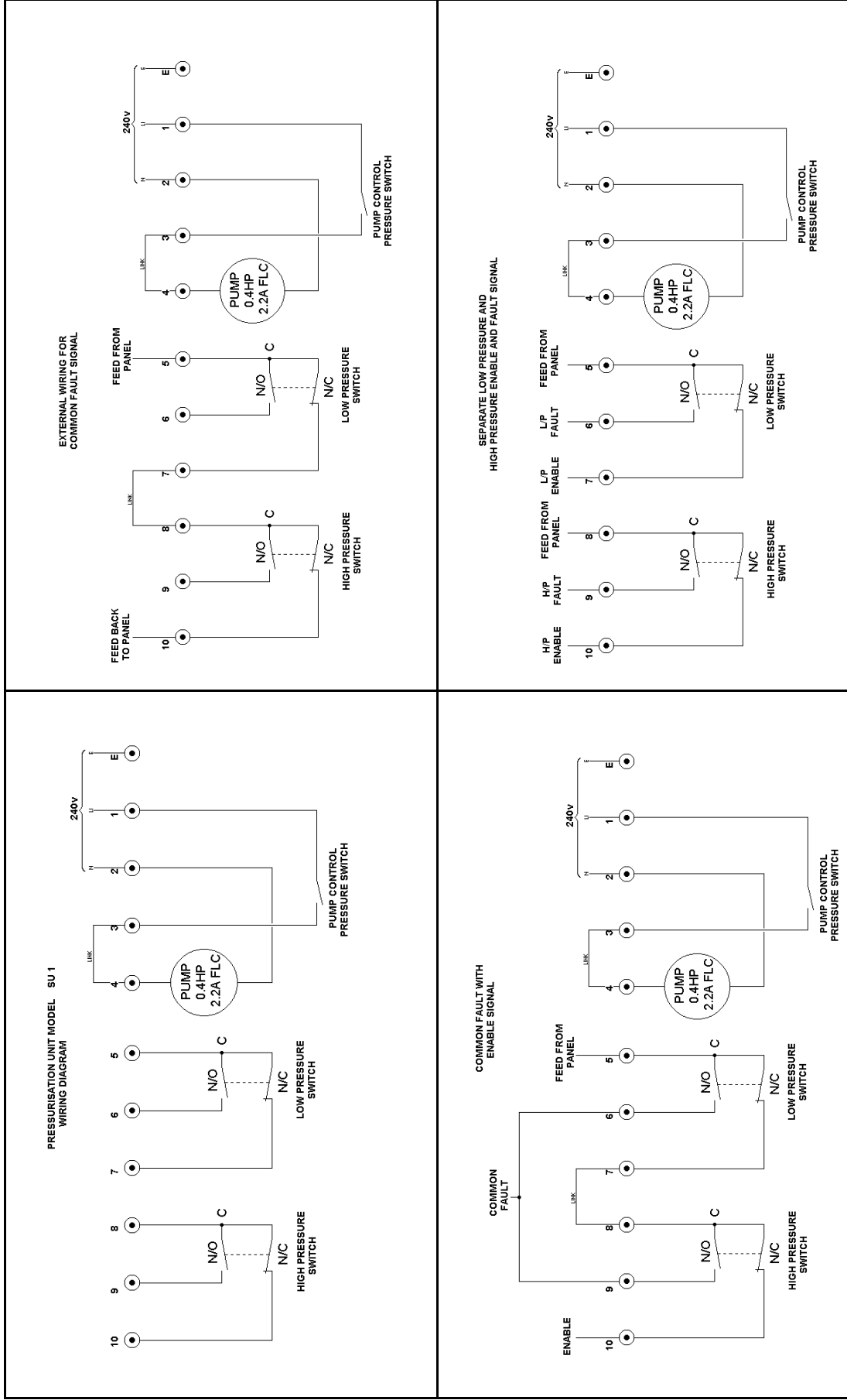

- Notes:
1. If a feed from mains input L1 is used as supply to fault indication switches, this will also warn of the pressurisation unit being electrically isolated.
  2. Only use feeds '6' and '9' to power lamps. Do not use for boiler interlock relays.
  3. We recommend that the main boiler relays are energised on a healthy system and de-energised on a fault or fail safe to protect boilers.



# Pressurisation Unit - SUE 1

**Legend:**

1. Mains isolator
3. Pump No.1 hand/off/auto select switch.
4. Pump No.1 running indicator. (G)
5. Pump No.1 tripped indicator. (A)
9. Power on Indicator. (W)
10. Low level Indicator. (A)
11. Low Pressure Indicator. (R)
12. High pressure indicator (R)

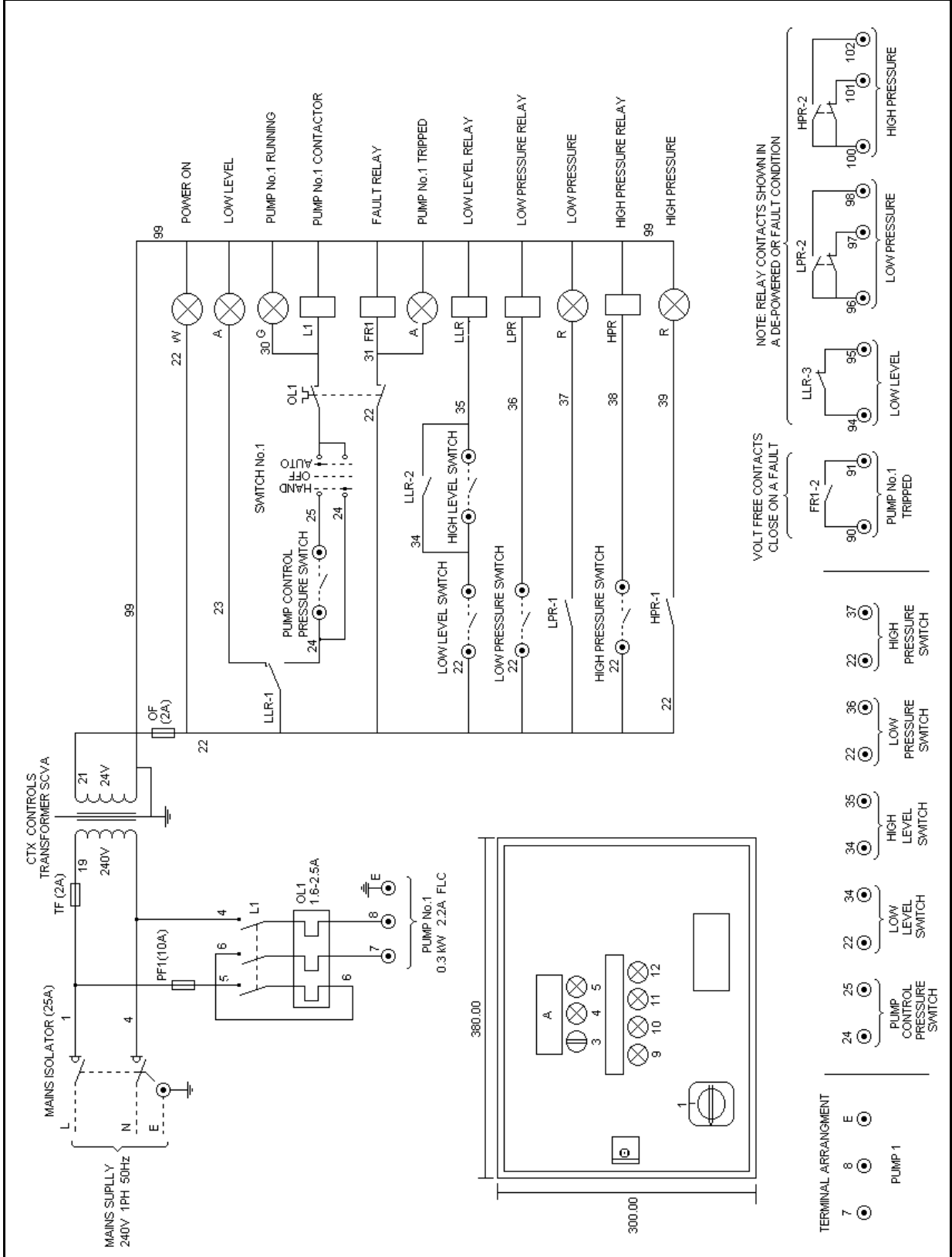

NOTE: RELAY CONTACTS SHOWN IN A DE-POWERED OR FAULT CONDITION

VOLT FREE CONTACTS CLOSE ON A FAULT

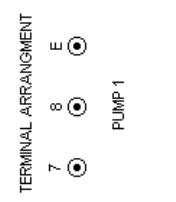

# Pressurisation Unit - SU 2

- Legend:**
- Duty select switch No.1/ OFF/No.2
  - Power on indicator (W)
  - Pump No.1 tripped indicator (A)
  - Pump No.2 tripped indicator (A)

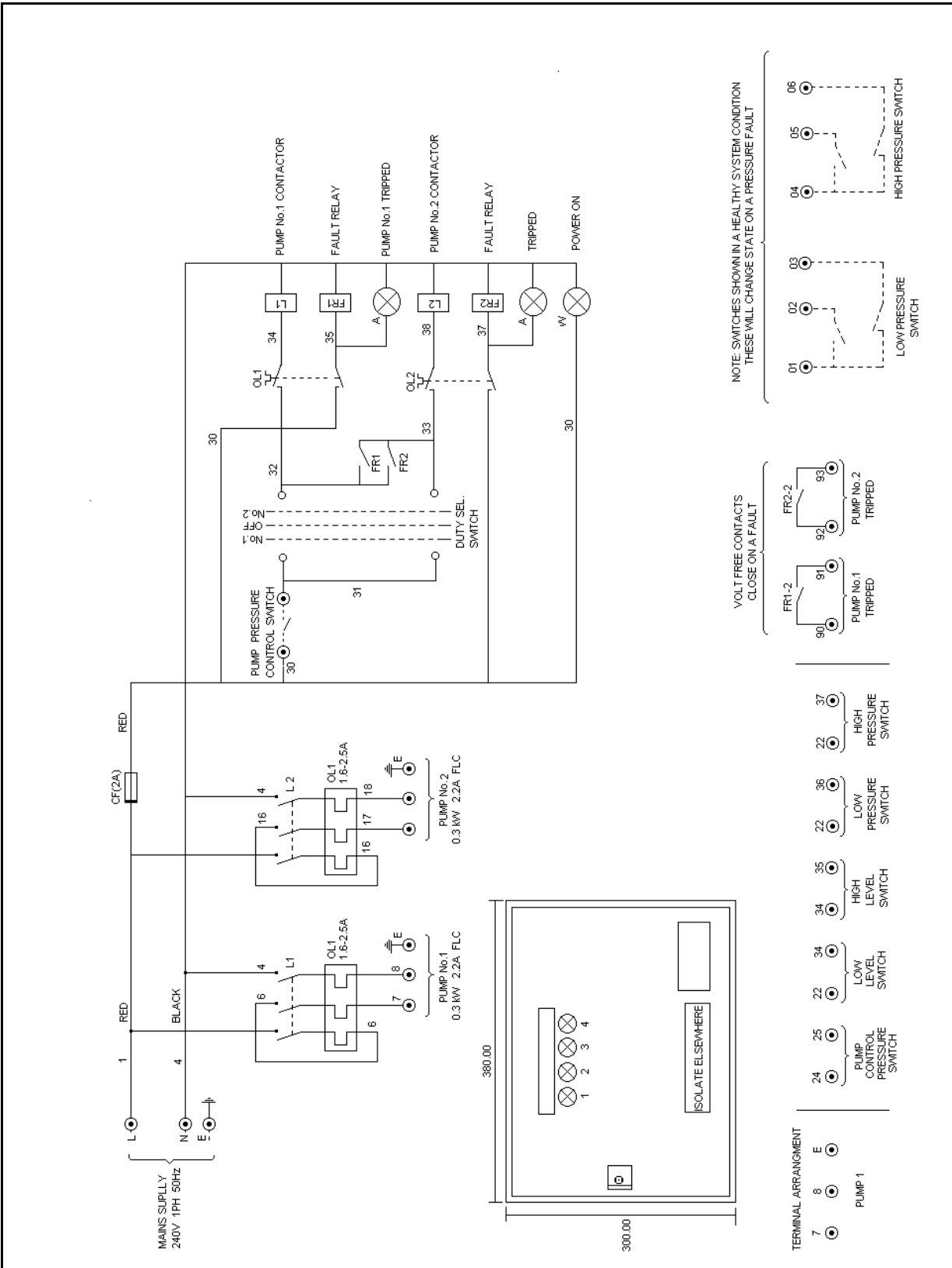

# Pressurisation Unit - SUE 2

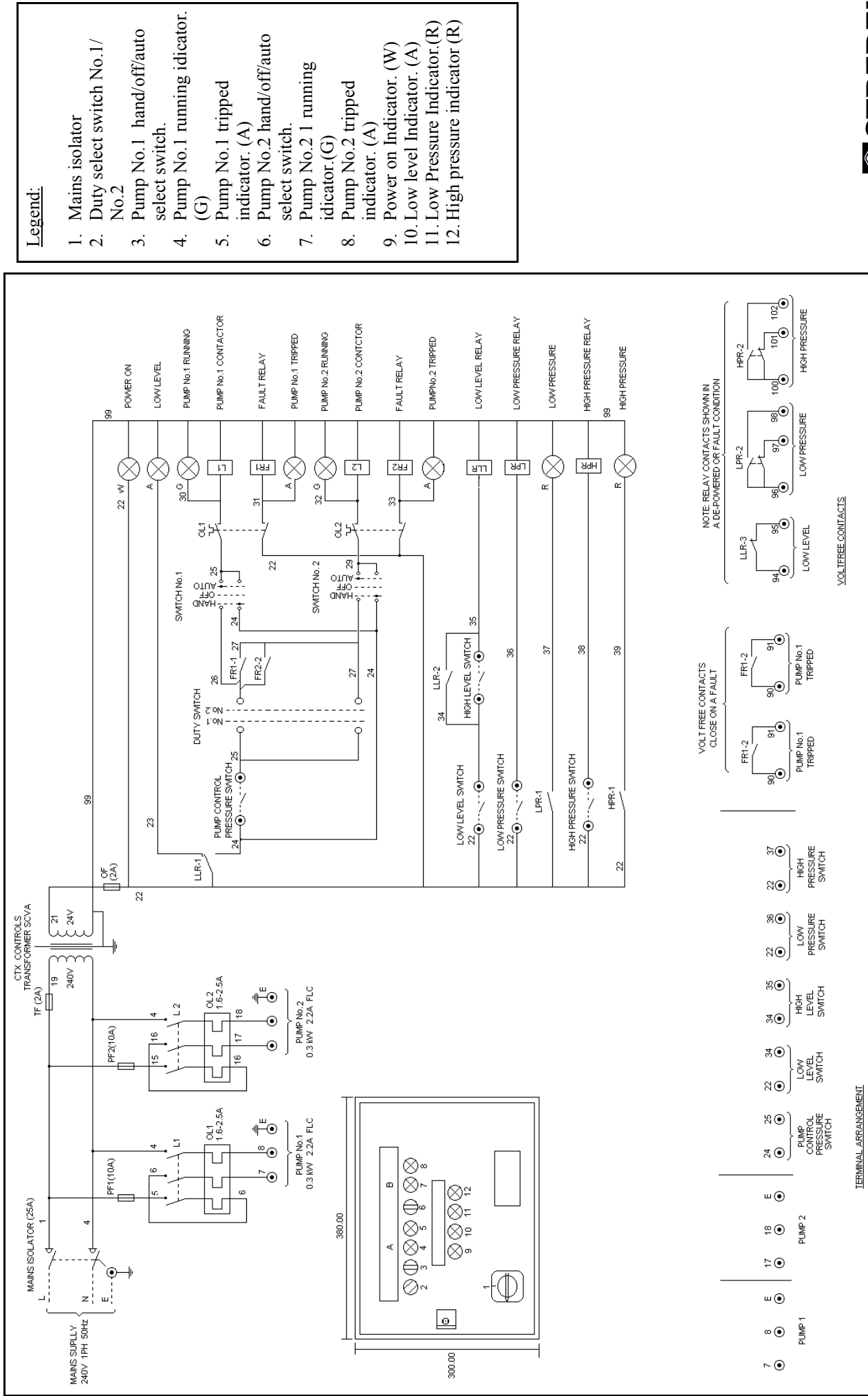

---

THE COMPANY RESERVES THE RIGHT TO CHANGE SPECIFICATIONS AND DIMENSIONS WITHOUT NOTICE

---

**STREBEL LTD**

1F Albany Park Industrial Estate  
Frimley Road, Camberley, Surrey, GU16 7PB  
Telephone: 01276 685422 Fax: 01276 685405  
E-mail address: [info@strebel.co.uk](mailto:info@strebel.co.uk)  
Website: [www.strebel.co.uk](http://www.strebel.co.uk)

---